

103-H7126-6640

SANYO DENKI
SANMOTION

Dimensions (Unit:mm)

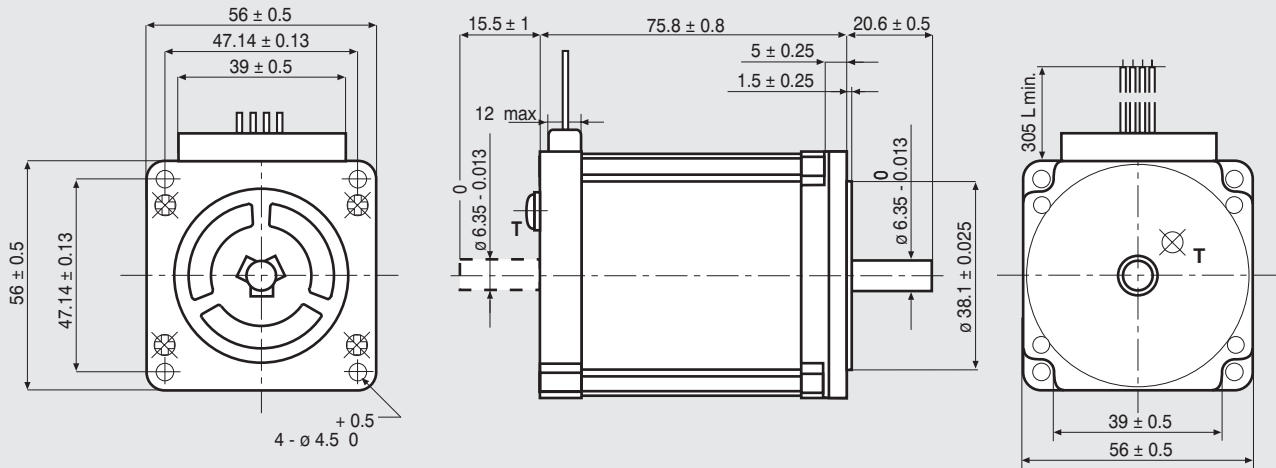

T IS THE EARTH TERMINAL

FEATURES

MODEL	103-H7126-6640 (103-H7126-6610)
BASIC STEP ANGLE	1.8° ± 0.09°
BIPOLAR CURRENT (Amp)	5.6
UNIPOLAR CURRENT (Amp)	
RESISTANCE (Ohm)	0.3
INDUCTANCE (mH)	0.85
BIPOLAR HOLDING TORQUE (Ncm)	165
UNIPOLAR HOLDING TORQUE (Ncm)	
ROTOR INERTIA (Kg ^m 2 x 10 ⁻⁷)	360
THEORETICAL ACCELERATION (rad x sec. ⁻²)	45800
BACK E.M.F. (V/Krpm)	23
MASS (Kg)	1
PROTECTION DEGREE	IP43
LEADS CODE	V

Codes between brackets refer to double shaft models.
Le sigle fra parentesi si riferiscono ai modelli bialbero.

TORQUE/SPEED CURVE

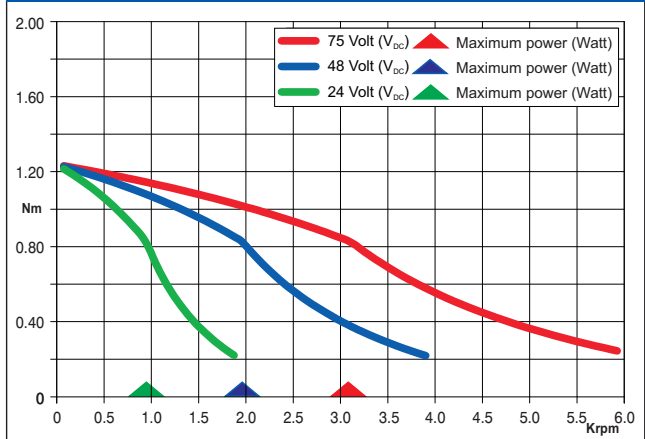

R.T.A. s.r.l. PAVIA (ITALY) SANYO DENKI CO., Ltd (JAPAN)



EMC - 10 - 14

Suggested R.T.A. driver: NDC/A-NDC Series, ADW Series, HGD Series, PLUS Series.



R.T.A. s.r.l.
Via E. Mattei - Fraz. Divisa
27020 MARCIGNAGO (PV) ITALY
Tel. +39.0382.929.855 - Fax +39.0382.929.150
www.rta.it

R.T.A. Deutschland GmbH
Bublitz Straße 34
40599 DÜSSELDORF (Germany)
Tel. +49.211.749.668.60 - Fax +49.211.749.668.66
www.rta-deutschland.de

R.T.A. IBERICA-Motion Control Systems S.L.
C/Generalitat 22, 1° 3°
08850 GAVA - BARCELONA (Spain)
Tel. +34.936.388.805 - Fax +34.936.334.595
www.rta-iberica.es